

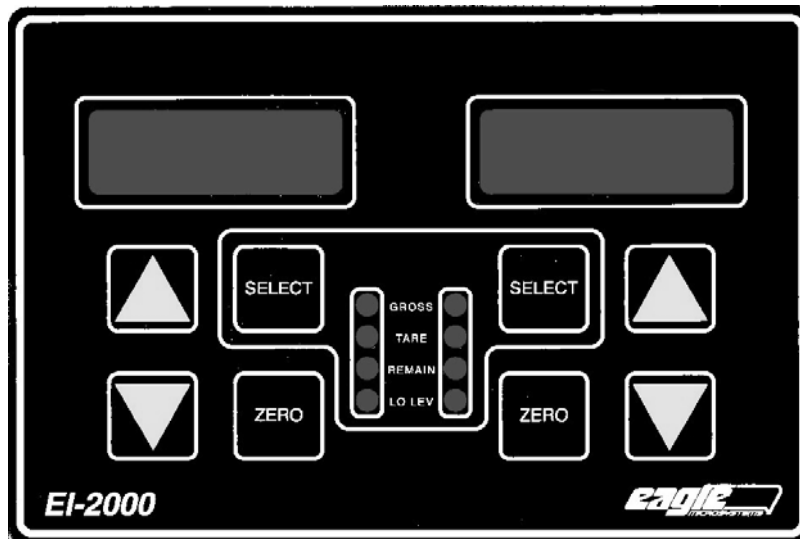

## OPERATING MANUAL

### EI-1000 & EI-2000

# DIGITAL WEIGH INDICATOR/TRANSMITTERS

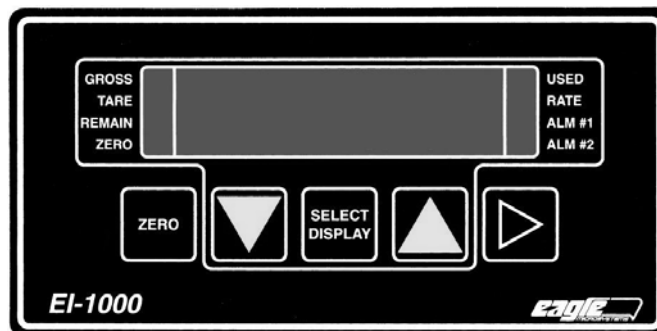

THIS MANUAL APPLIES TO EI-2000/1000 FIRMWARE VERSION 4.20 OR ABOVE

Revised: 2007-08-14

EAGLE MICROSYSTEMS, INC.  
366 CIRCLE OF PROGRESS  
POTTSTOWN, PA 19464

*Page is intentionally blank...*

### EI-1000 FEATURES

- Up to four scale bases
- User selects scale base via front panel keypad.
- Up to four continuous 4-20mA outputs
- Six-digit display for up to 999,000 lb or kg scale displays.
- Up to ten relay outputs

### EI-2000 FEATURES

- Up to two scale bases
- Simultaneous display of both channels via the dual four-digit display.
- Two 4-20mA outputs
- Up to ten relay outputs

### EI-2000S BOARD OPTIONS

The following options must be specified at the time of ordering.

<b>Set point relays</b>	Adds two, 3A, 250V DC/AC, mechanical relay contact outputs
<b>RS485</b>	Adds a two wire RS485 interface
<b>RTC</b>	Adds time & date

### OPTION BOARDS

#### **EI-2000-EXP**

This board mounts on the EI-2000S-CPU board. It furnishes two additional scale inputs, two additional relay contacts, and two 4-20mA analog outputs.

#### **EI-2000-IO**

This board mounts on the EI-2000S-CPU board. It furnishes eight additional relay contacts and four remote switch inputs.

Note: If both option boards are needed, they are mounted off-board and connect to the EI-2000S-CPU via ribbon cables.

### SPECIFICATIONS

#### **Power Supply**

A.C. Voltage (switch selectable): 115V/230V  
Power: 12W

#### **Relays**

Type: Form-A (N/O)  
Current capacity: 3A  
Maximum V. AC: 250V  
Maximum V D.C. 250V  
Mechanical: Yes

#### **Environmental**

Temperature range: -10C to 40C  
Humidity (non-condensing): 2%

#### **Loadcell**

Current Capacity 240mA  
Excitation Voltage 5V +/- 0.25V  
Remote Sense Scale 1 only

#### **Analog outputs**

Compliance: 10V  
Load: <510ohms  
Current range: 0 – 22mA

**Real Time Clock** Optional

#### **Serial I/O**

RS232 Standard  
RS485 Optional

## PUSHBUTTONS

The EI-2000 has a set of pushbuttons for each of the two channels, and the EI-1000 has one set of pushbuttons that control up to four channels (scale bases). The pushbutton functions listed below describe their typical uses. However, when applicable, the pushbutton(s) may be used for other functions, which is documented in this manual.



**EI-1000 PUSBUTTONS**

<b>ZERO</b>	Press to zero the gross or used weight.
<b>DOWN ARROW</b>	Press to decrement (decrease) the value displayed if it's adjustable.
<b>SELECT</b>	Select gross, tare, remaining, etc. This pushbutton is used for many other functions, as well.
<b>UP ARROW</b>	Press to increment (increase) the value displayed if it's adjustable.
<b>RIGHT ARROW</b>	EI-1000 only: Selects a channel or exits from front panel configuration/calibration access.

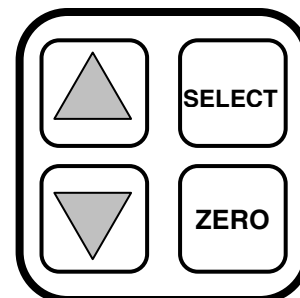

**EI-2000 PUSBUTTONS**

## DISPLAYS

The main operating mode of the meter is, of course, viewing the weight on the scale(s) connected to each channel. One can select, via the appropriate SELECT pushbutton, several weight values; they are as follows:

### **Gross weight**

This is the total weight on the scale, which includes the weight of the container (e.g., cylinder, tank, or barrel) and the weight of the product.

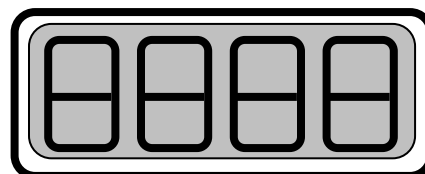

### **Tare weight**

This is the weight of the container (e.g., cylinder, tank, or barrel).

### **Remaining weight (a.k.a. net weight)**

This is the weight of the product (e.g., Chlorine) that the container holds.

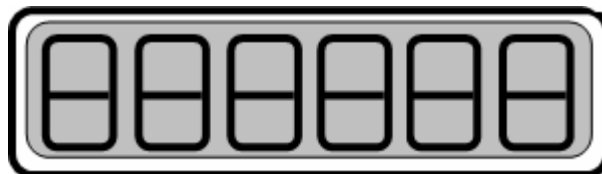

### **Used weight**

This is the weight of the amount used since the scale was last zeroed, which is done by either "starting" the channel (operating modes 2, 3, and 4) or pressing the ZERO pushbutton while viewing this display. The EI-2000 display will alternate between a "USEd" message and the actual used weight value. This value increases with decreasing weight on the scale since it represents the amount of product used so far.

## LED INDICATORS

LED	EI-1000	EI-2000	SOLID	FLASHES
<b>GROSS</b>	√	√	Gross weight is being displayed	Gross weight is adjustable (CAL)
<b>TARE</b>	√	√	Tare weight is being displayed	Flashes when the TARE has the lock enabled indicating that the tare is adjustable.
<b>REMAIN</b>	√	√	Remaining weight is being displayed.	The <u>tare</u> LED flashes when the remaining weight is adjustable.
<b>LO LEV</b>		√	The weight on the scale is below the low-level set point.	Never
<b>ZERO</b>	√		Not used at this time.	Never
<b>USED</b>	√		Used weight is being displayed.	Never
<b>RATE</b>	√		Not used at this time.	Never
<b>ALM #1</b>	√		Same function as the LO LEV that is described above (set point A).	Never
<b>ALM #2</b>	√		Same function as the LO LEV that is described above (set point B).	Never

## POUND (lb) AND KILOGRAM (kg) UNITS OPERATION

The EI-1000 and EI-2000 meters may operate using lb or kg units. DIP switch S1-3 selects the desired unit. If one wishes to switch to the other unit, simply flip the switch to the opposite setting; no recalibration is necessary. It is necessary to select the proper S1-3 switch setting so the unit selection works properly (i.e., do not calibrate the scale in kg if the S1-3 switch is set to lbs). Also, all parameters that were set using the previous units are converted to the equivalent value of the newly selected unit.

## EI-1000 CHANNEL/SCALE BASE SELECTION

If more than one channel is enabled, the RIGHT ARROW pushbutton selects which channel currently being displayed. Note: The first press of the RIGHT ARROW pushbutton displays, for one-second, the selected channel (CH x).

## OPERATING MODES

The EI-1000 & EI-2000 meters have five operating modes to simplify user interactions with the meter. The descriptions below will reference the set of pushbuttons for the left or right (CH1 or CH2) channel on the EI-2000 or the set of pushbuttons on the EI-1000 that control all, up to four, scales. Configuration parameter P001 selects which operating mode, 1 thru 5, is enabled for all scales.

### **MODE 1: FULLY MANUAL MODE**

Typical application: drum scales, bin and hopper scales - Remaining, tare, & gross weights are displayable.

1. An empty scale should read zero. If it does not, press the ZERO pushbutton. If “no 0” is displayed, access the calibration mode to zero the scale.
2. Place container on the scale.
3. Press the SELECT pushbutton to go to the tare weight.
4. If necessary, adjust the tare weight value via the arrow pushbuttons.
5. Press the SELECT pushbutton to go to the remaining weight.

## **MODE 2: ADJUSTABLE REMAINING**

Typical application: drum scales - Remaining & gross weights are displayable.

1. An empty scale should read zero. If it does not, press the ZERO pushbutton. If “no 0” is displayed, access the calibration mode to zero the scale.
2. Place container with product on the scale.
3. Instrument will show the REMAINING weight and will flash the tare LED.
4. Use the UP and DOWN arrow pushbuttons to adjust the remaining weight displayed.
5. Press the SELECT pushbutton, the tare LED will stop flashing.

If you need to adjust the REMAINING weight again, press and hold either the UP or DOWN arrow pushbutton for 3 seconds, the tare LED will start to flash and the remaining weight will now be adjustable. Press the SELECT pushbutton when finished.

## **MODE 3: AUTOMATIC OPERATION**

Typical application: full cylinders/tanks - Remaining and gross weights are displayable.

1. An empty scale should read zero. If it does not, press the ZERO pushbutton. If “no 0” is displayed, access the calibration mode to zero the scale.
2. Place a full container on the scale; the Gross LED will flash.
3. Adjust gross weight by using the UP and DOWN arrow pushbuttons.
4. Press the SELECT pushbutton; the tare weight will be automatically calculated and stored in memory. The preset “START” value (configuration parameter Px17) of remaining chlorine weight will now be displayed, and the REMAIN LED is illuminated.

If the REMAINING weight must be adjusted again, one should press and hold either the UP or DOWN arrow pushbutton for 3 seconds. The tare LED will start to flash and the remaining weight will now be adjustable. Press the SELECT pushbutton when finished.

## **MODE 4: ADJUSTABLE TARE**

Typical application: partially used chlorine cylinders - Remaining, tare, & gross weights are displayable.

1. An empty scale should read zero. If it does not, press the ZERO pushbutton. If “no 0” is displayed, access the calibration mode to zero the scale.
2. Place a full container on the scale.
3. The Gross LED will flash.
4. Adjust gross weight by using the UP and DOWN arrow pushbuttons.
5. Press SELECT, tare will now be displayed (tare LED should be illuminated).
6. Adjust tare, as required, by using the UP and DOWN arrow pushbuttons.
7. Press SELECT, the remaining weight will now be displayed (REMAIN LED should be illuminated).

## **MODE 5: USER-ADJUSTABLE REMAINING**

Typical application: chlorine gas cylinders. - Remaining and gross weights are displayable.

1. An empty scale should read zero. If it does not, press the ZERO pushbutton. If “no 0” is displayed, access the calibration mode to zero the scale.
2. Place a full container on the scale.
3. “REMAIN” LED will light.
4. Use the UP and DOWN ARROW pushbuttons to adjust the remaining weight displayed.
5. The SELECT pushbutton will toggle display between gross and remaining weights.

*Note: This operating mode mimics the standard modes of other manufacturer’s scales. The ability to display the true “Gross” weight value allows the operator to verify the remaining value displayed; overfilled cylinders can be detected.*

### **!! CAUTION !!**

***IN MODES 2 & 5, THE DISPLAYED “REMAINING” VALUE CAN BE EASILY CHANGED TO GIVE AN ERRONEOUS READING. BEFORE REMOVING THE VALVE FROM AN “EMPTY” CYLINDER OR OPENING THE VALVE ON A FULL CYLINDER, ALWAYS VERIFY REMAINING VALUE WITH THE GROSS WEIGHT.***

**REMAINING\_WEIGHT = GROSS\_WEIGHT - CYLINDER\_WEIGHT - VALVE\_WEIGHT.**

### **HIDDEN PUSHBUTTON FUNCTIONS**

#### **Scale gross weight recalibration/restart:**

When a cylinder or tank is on the scale (above the weight threshold in modes 2-5, see parameters P116, P216, etc.), press and hold the SELECT pushbutton until the gross LED is starts to flash. At this time, the user may now use the UP and DOWN arrow pushbuttons to adjust the gross scale calibration. When satisfied that the weight is correct, press the SELECT pushbutton to restart the scale. Depending on the operating mode, a new start remaining weight will be calculated and the used display will be zeroed.

#### **Tare lock:**

If this function is enabled (parameter P030), operating modes that display the tare weight (modes 1 and 4), will not allow adjustment of the tare weight without first holding the UP or DOWN arrow pushbutton for three seconds. To store the new tare, press the SELECT pushbutton to display the remaining weight.

### **Front Panel Configuration/Calibration/Diagnostic Access (FPA)**

The user has the option of accessing ALL configuration, calibration and diagnostic functions without opening the enclosure. Parameter P999 selects whether or not this is enabled (it is set to no or yes).

*EI-1000: Press and hold [SELECT] + [RIGHT ARROW] for greater than three seconds.*

*EI-2000: Press and hold [LEFT SELECT] + [RIGHT SELECT] for greater than three seconds.*

When the **FPA menu** is first displayed, the CFG option is shown. The selections are configuration (CFG), calibration (EI-2000 has CAL and the EI-1000 has CAL1 through 4),

analog output (AOUt), and diagnostic (dIAG). Press the UP or DOWN ARROW pushbutton below to select another mode, and press the “enter” pushbutton to select the function:

Menu choice selection:

*EI-1000: [DOWN ARROW] or [UP ARROW]*

*EI-2000: [RIGHT UP ARROW] + [RIGHT DOWN ARROW]*

To make a selection, press...

*EI-1000: [SELECT]*

*EI-2000: [RIGHT SELECT]*

To exit the calibration/configuration/diagnostic mode, press...

*EI-1000: [RIGHT ARROW]*

*EI-2000: [LEFT SELECT]*

The user will be returned to the FPA menu. The user can either select another menu choice using the UP ARROW or DOWN ARROW (plus SELECT) pushbuttons or exit back to the weigh mode by pressing the pushbutton stated above.

## **CONFIGURATION**

To enter configuration, either set the DIP switches to S1-1=ON, S1-2=OFF, and S1-4=OFF or use the front panel access method.

### **EI-1000 PUSHBUTTONS**

To select a parameter, press the UP ARROW or DOWN ARROW pushbutton; the parameter label (Pxxx) is displayed and then its value is displayed (alternates the two).

To adjust a parameter, press the SELECT pushbutton; the current parameter value will flash. Using the UP ARROW and DOWN ARROW pushbuttons, adjust the value to the desired setting. Finally, press the SELECT pushbutton again to enter the new value.

### **EI-2000 PUSHBUTTONS**

Select a parameter by the LEFT UP and DOWN ARROW pushbuttons, and adjust the value by the RIGHT UP and DOWN ARROW pushbuttons.

#### **P001 Operation (1 – 5)**

This selects the operating mode for the meter. See the “operating mode” section of this manual for a detailed description of each one.

#### **P010 lb/kg (display only)**

This displays the engineering unit, lb or kg, selected by S1-3. The user can change the units DIP switch at any time; all values that were entered in pounds are automatically converted to kilograms and vice versa.

#### **P020 Used display enable/disable (ON/OFF)**

If set to on, the used display is available to be selected via the select pushbutton.

### P030 Tare lock enable (Y) or disable (N).

This applies to operational modes 1 & 4. While viewing the tare value, press and hold the up or down arrow pushbutton. After three seconds, the tare value will be adjustable. Also, the tare LED will flash. Press the select pushbutton to view the remaining weight and to store the tare value permanently.

### SCALE PARAMETERS

P100 through P400 set needed parameters for the attached scale bases. If a scale base is set to OFF, this applies to channels 2, 3 and 4; all of its parameters are hidden except for the scale selection.

- P100-P199 Scale 1 parameters
- P200-P299 Scale 2 parameters
- P300-P399 Scale 3 parameters (EI-2000-EXP must be installed)
- P400-P499 Scale 4 parameters (EI-2000-EXP must be installed)

### P100 Scale selection (auto-configuration)

This parameter selects the Eagle Microsystems scale connected to the scale channel input

Px00	Function
OFF	This turns the channel off if it's not needed (2, 3 and 4).
CY-1	Copy the channel 1 setup; this is available for channels 2, 3, and 4. The parameters and set points are hidden since they are identical to channel 1.
USER	All scale parameters are available.
1 & up	This selects a scale, see scale selection table below. All parameters are automatically setup. The resolution and average parameters (Px11 & Px12) can be changed.

**SCALE SELECTION TABLE**

	Px00	Px10	Px11	Px12	Px13	Px16	Px17
Select	Scale type	F.S.	Res.	AZ	PTZ/AZ range	Threshold weight	Start weight
		<i>lb/kg</i>	<i>lb/kg</i>	<i>%</i>	<i>%</i>	<i>lb/kg</i>	<i>lb/kg</i>
1	DCS302	300/140	0.5/0.2	1%	2%	60/27.2	150/136
2	EDS400	400/180	0.5/0.2	1%	2%	60/27.2	150/136
3	DS750	750/340	0.5/0.2	1%	2%	60/27.2	150/136
4	WT3600 (1/ch)	4000/1810	5/2	1%	10%	1000/454	2000/907
5	WT3600 (2/ch)	8000/3630	5/2	1%	10%	1000/454	4000/1816
6	LP4300 /4000lb.	2000/910	1/0.5	1%	2%	50/23	2000/910
7	LP4300/12000lb.	6000/2720	1/0.5	1%	2%	50/23	6000/2720
8	ECS150x	300/140	0.5/0.2	1%	2%	60/27.2	150.0/68.0
9	WP1000 (300lb)	300/140	0.5/0.2	1%	2%	60/27.2	150.0/68.0
10	*WT3600 (1/ch)	4190/1900	5/2	1%	10%	1000/454	2030/920
11	*WT3600 (2/ch)	8380/3800	5/2	1%	10%	1000/454	4060/1840
12	WP1000 (600lb)	600/280	0.5/0.2	1%	2%	120/54.4	150.0/68.0
13	WP1000 (1200lb)	1200/560	0.5/0.2	1%	2%	240/108.8	150.0/68.0
14	LP4310						

\*Australian typical load settings.

## Scale Selection (cont.)

To load default scale calibration for the scale selected above, press and hold the RIGHT SELECT (EI-2000)/SELECT (EI-1000) pushbutton until LOAD YES/NO (Y/n) appears. Press the (RIGHT) UP ARROW to select yes or no (Y/n) and then press the (RIGHT) SELECT again to enter your choice. This also must be done for channels two through four (if enabled).

### **P110 Full-scale (10 to 9900)**

This sets the full-scale in the units selected by the lb/kg switch, S1-3. This is used to limit set points and other parameters that are entered using lb or kg weighing units.

### **P111 Resolution (0.0001 to 500)**

This sets the weight division for the unit selected by the lb/kg switch. The choices for the EI-2000 are 0.1, 0.2, 0.5, 1, 2, and 5. The choices for the EI-1000, since it has a six digit display, are extended to the range of 0.0001 to 500.

### **P112 Average (1, 2, 4, 8, 12, 16, or 20)**

This parameter sets the number of scale weight acquisitions before the display is updated to the weight on the scale. Higher numbers yield a more stable less responsive meter reading.

### **P113 Auto-zero (off, 0.01, 0.02, 0.03, 0.05, 0.1, 0.2, 0.3, 0.5, 1, 2)**

Auto zero is used to automatically zero the meter (same as pressing the zero pushbutton). This setting controls how much of scale range in percentage will automatically be zeroed when the load (e.g., container, tank or cylinder) is remove from the scale. All negative values are zeroed regardless of this setting unless it is set to off.

Example: If full-scale is 300lbs and auto-zero is set to 0.5 (%), the weight must be below 1.5lbs for the meter to automatically zero the scale.

### **P114 Push to Zero/Auto-zero PTZ/AZ maximum range (2, 5, 10, 20, 50, or ALL).**

When the load is removed from the scale, in an ideal world, the weight returns to zero. However, usually the meter reading is above zero. If the auto-zero is enabled (Px13) and the weight is within its range, the meter will automatically zero the weight. If it's not, the user should press the zero pushbutton for the selected channel.

The PTZ/AZ parameter, set in percentage of full-scale, selects the maximum amount of weight that is permitted to be zeroed either automatically or by pressing the zero pushbutton.

Example: If full-scale is 300lbs and **PTZ/AZ** is set to 2 (%), the weight must be below 6 lbs for the meter to allow the automatic zero (AZ), if enabled, to zero the scale or the ability to zero the scale via the ZERO pushbutton. Note: If the threshold (Px16) weight is exceeded, the automatic zero and pushbutton zero are inhibited.

Note: The "ALL" setting allows unlimited zeroing ability, which is not a recommended setting since the scale load-cell may be shifting too much.

**P116 Threshold (0 to full-scale)**

This applies to operating modes 2 through 5. This sets the point (in lbs or kgs) that the meter will enable, depending on the operating mode, switching to remaining or enabling adjustment of the gross weight calibration or remaining weight.

**P117 Start (0 to full-scale)**

This parameter applies to operating modes 3 & 4. This is the value of the remaining weight (in lbs or kgs) when the scale channel is “started.” See the “operating modes” section of this manual.

**P2xx, P3xx & P4xx**

Parameters P2xx, P3xx and P4xx are identical to the P1xx set but control scale bases two through four, respectively. Inactive channel parameters are hidden. If the EI-2000-EXP is not installed, P3xx and P4xx parameters are not available.

**P500 Set point A mode selection**

<b>Off</b>	Set points are disabled
<b>Lo(w)-level</b>	Low-level, remaining weight set point
<b>Hi level</b>	High-level, remaining weight set-point

The set points have a 1% hysteresis (based on the full-scale) and an activation delay of three seconds. For example, if the full-scale is 300lbs, the set point is 10lbs, and the low-level set point mode is selected, the relay is energized when the remaining weight is equal to or below 10lbs for three seconds. The relay is de-energized when the remaining weight goes above 13lbs. If the high-level set point is enabled, the relay is also energized at 10lbs, but it’s de-energized at 7lbs.

**P501 Set point B mode selection**

This parameter is used if either the EI-2000-EXP or EI-2000-I/O board is installed or if the EI-1000 meter has only one channel enabled. The selections are identical to the P500 parameter.

**P510 Set point A value for channel 1****P511 Set point B value for channel 1****P520 Set point A value for channel 2****P521 Set point B value for channel 2****P530 Set point A value for channel 3****P531 Set point B value for channel 3****P540 Set point A value for channel 4****P541 Set point B value for channel 4**

These are the set point values for each channel; they are set in lb or kg units, depending on the unit selection switch, S1-3.

The diagram to the right shows an example of relay contact wiring.

The relay specifications are mechanical, 3A, & 250VAC/250VDC maximum.

TB2 contacts are “dry” (potential free), so the load power supply is external, see the example circuit to the right.

If the load is inductive, add a **snubber** (RC) circuit across the relay contact terminals to greatly extend the life of the relay contacts.

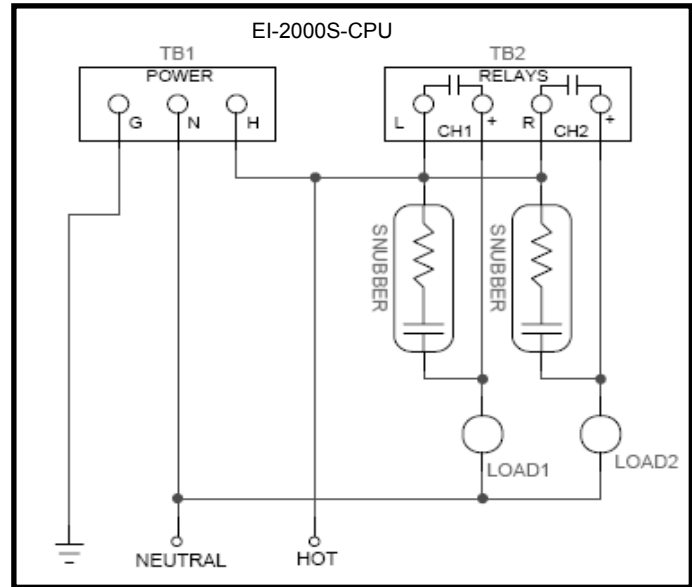

### RELAY ASSIGNMENTS (SET POINT)

METER	K1 (CH1)	K2 (CH2)	*K3 (CH3)	*K4 (CH4)
EI-1000	CH1 (P510)	CH1 (P511)	CH2 (P520)	CH2 (P521)
EI-2000	CH1 (P510)	CH2 (P520)	CH1 (P511)	CH2 (P521)

\*Requires installation of the EI-2000-EXP or EI-2000-IO.

### P600 Analog output type selection

Analog output: rE (remaining weight) or Gr (gross weight)

This selects the weight that is transmitted via the 4-20mA analog outputs.

**P610 Analog output 20mA (full-scale) weight for channel 1**

**P620 Analog output 20mA (full-scale) weight for channel 2**

**P630 Analog output 20mA (full-scale) weight for channel 3**

**P640 Analog output 20mA (full-scale) weight for channel 4**

A 20mA analog signal is transmitted when the weight is equal to the value set by the above parameters. A current of 4mA is transmitted when the weight, selected by P600, is equal or less than zero. The analog outputs do not go below 4mA or above 20mA under normal operation.

### SERIAL INTERFACE PARAMETERS

**RS232 and RS485 serial interface control parameter(s):**

**P701 Baud Rate**

Select the serial port baud rate (default = 9600). The selections are 300, 600, 1200, 2400, 4800, 9600 & 19200 (19.2K) baud.

*Note: See the section labeled SERIAL COMMANDS for more information.*

### MISCELLANEOUS PARAMETERS

**P999 Front panel cal/cfg access (FPA)**

Enable or disable (ON or OFF) this function; see the “Front Panel Configuration/Calibration/Diagnostic Access (FPA)” section of this manual.

## ANALOG OUTPUTS

The EI' series furnishes an analog 4-20mA (milliamp) signal for transmission to a remote system such as a SCADA or RTU for each channel (up to four). From the factory, the calibration is within 0.5% of 4mA and 0.5% of 20mA or better. Therefore, it is recommended that one performs a 4-20mA calibration adjustment for each channel if a more accurate matching between the meter and user system is required.

To access the analog output calibration/test mode, close S1-2 (S1-1 & S1-4 are open) or use the FPA sequence. These parameters are used to calibrate the 4 - 20mA analog output points for each channel. See the table below for push-button functionality. NOTE: Left zero, left select, right zero & right select have no function in Analog Output Configuration.

### **EI-2000**

*Left, up and down arrow pushbuttons*    *Select a parameter*

*Right, up and down arrow pushbuttons*    *Alter the value of the parameter*

### **EI-1000**

*UP/DOWN arrows select a parameter.*

*To alter the value of a parameter, press the SELECT pushbutton. Use the UP/DOWN ARROWS pushbuttons to set the desired value and then press the SELECT pushbutton when finished.*

### **PARAMETER EI-1000: Ao.tESt**

### **PARAMETER EI-2000: Ao t xx.xx**

This parameter tests both Digital to Analog Converters using ten, linear 1.6mA steps from 4.00 mA to 20.00 mA.

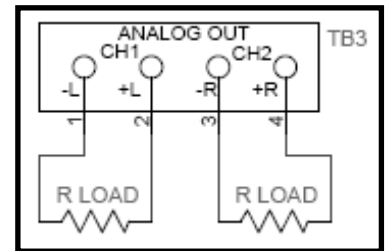

The analog outputs are active (self powered). Therefore, the load must be passive (voltage/potential free) so no damage occurs to the EI-2000S-CPU or the user's system. The "R LOAD" resistance can range from 0 to 510 ohms. When one is calibrating the analog outputs, the "R LOAD" represents the DMM or 4-20mA calibrator device.

**Note: The -L & -R (terminals 1 & 3) are connected and this must be taken into consideration when connecting the load to the analog outputs. Refer to schematic above.**

## **ANALOG 4mA and 20mA POINT ADJUSTMENT PARAMETERS**

Each analog output is calibrated to 4mA and 20mA points, so each of the up to four analog outputs has a 4mA and 20mA point setting – see the parameters below:

### **EI-1000**

ANALOG OUTPUT 4.00 mA (ZERO) ADJUSTMENT: EI-1000

**PARAMETER EI-1000: Ao.x** (x = 1,2,3, or 4) Press

Set the left 4.00 mA analog output point using the up & down arrow pushbuttons. The display will not show any indication that the left analog output is changing which is why one should have a "mA" meter (i.e., DMM) connected to the appropriate output. The mA output range is approximately 4.0 mA +/- 1.0 mA.

ANALOG OUTPUT 20.00 mA (SPAN) ADJUSTMENT: EI-1000

**PARAMETER EI-1000: Ao.x** (x = 1,2,3, or 4)

Set the left 20.00 mA analog output point using the right up & down arrow pushbuttons. The display will not show any indication that the left analog output is changing which is why one should have a "mA" meter (i.e. DMM) connected to J3-1 & J3-2. The mA output range is approximately 20.0 mA +/- 1.0 mA.

### **EI-2000**

ANALOG OUTPUT 4.00 mA (ZERO) ADJUSTMENT: EI-2000

**PARAMETER EI-2000: "AO x" "4.00"** (x = 1,2,3, or 4)

Set the left 4.00 mA analog output point using the right up & down arrow pushbuttons. The display will not show any indication that the left analog output is changing which is why one should have a "mA" meter (i.e., DMM) connected to the appropriate output. The mA output range is approximately 4.0 mA +/- 1.0 mA.

ANALOG OUTPUT 20.00 mA (SPAN) ADJUSTMENT: EI-2000

**PARAMETER EI-2000: "AO x" "20.00"** (x = 1,2,3, or 4)

Set the left 20.00 mA analog output point using the right up & down arrow pushbuttons. The display will not show any indication that the left analog output is changing which is why one should have a "mA" meter (i.e. DMM) connected to J3-1 & J3-2. The mA output range is approximately 20.0 mA +/- 1.0 mA.

## DIAGNOSTICS

The diagnostic mode is an advanced mode that one can use to restore scale calibration and read the raw scale output in mV/V (millivolt per volt). One enters the diagnostic mode by either the DIP switches (S1-1 & 2 = ON & S1-4=OFF) or by the front panel access method.

### **1.U, 2.U, 3.U, or 4.U: Scale mV/V signal**

This displays the scale mV/V signal (terminals +S & -S) for each channel. The normal range for an empty scale is from -0.1mV/V to 0.1mV/V. However, if there is a vessel, tank, etc. (with no product) attached or sitting on the scale, this value can be higher than 0.1mV/V. The nominal range with product on the scale is from 0mV/V to 3mV/V.

A DMM measuring the actual mV at the signal terminals would read about five times the value read here (e.g., a 1mV/V “1.U” display would show as 5mV on a DMM).

## **DIAGNOSTIC CALIBRATION READ/ENTRY**

The following parameters allow one to read and re-enter calibration zero and span. These parameters are used for approximate calibration if one does not have test weights or the ability to remove the weight from the scale. Entering these values, if calculated and entered correctly, will yield a 0.25% or better calibration for each channel.

In order to use these parameters, the scale mV/V at a specific lb/kg weight (e.g., 3mV/V at 4000lbs) must be known - this is the “(scale) FULL SCALE” entry that’s written on the EI’ routing sheet.

### **1.o, 2.o, 3.o, & 4.o: Scale calibration dead-zero (one for each active channel)**

The scale mV/V dead-zero value represents the weight of the platform and, possibly, a fixed tank. NOTE: This value does not include the weight a removable cylinder or tank. Any PTZ/AZ values are not added to the zero value displayed.

$$\text{DEAD ZERO} = \frac{[\text{FS mV/V}]}{[\text{FS WT (lb/kg)}]} \times [\text{Assumed dead weight WT (lb/kg)}]$$

Example: If the scale full-scale is 3mV/V @ 4000lbs and the assumed dead weight is 500lbs, the value one would enter into the dead zero value parameter is 0.3750.

### **1.c, 2.c, 3.c, & 4.c: Scale calibration span (one for each active channel)**

Scale calibration value, this is the load that is typically removable that includes the weight of the product and container combined. Use the formula below to calculate an approximate calibration factor that’s entered into this parameter. To shift the decimal point, press the RIGHT ARROW pushbutton on the EI-1000 or the RIGHT SELECT pushbutton on the EI-2000.

$$\text{CAL} = \frac{[\text{FS WT (lb only!)}]}{[\text{FS mV/V}]}$$

Example: If the scale full-scale is 3mV/V @ 4000lbs, the CAL value entered is 1333.3.

**Note: If the full scale weight is in kilograms (kg), multiply the weight by 2.2046 and then divide it by the full scale mV/V value.**

## SERIAL COMMANDS

### Send gross weight

SGW **x**<CR>

Where **x** selects the channel (1, 2, 3, or 4); if **x** is not specified, all four channels are transmitted. The box to the right shows the response to this command.

```
000000000011111111112222222222233333333334444 4 4
01234567890123456789012345678901234567890123 4 5
Gross 162.5, 195.0, 0, 0 lb<CR><LF>

00000000001111111 1 1
01234567890123456 7 8
Gross 195.0 lb<CR><LF>
Gross 73.6 kg<CR><LF>
```

### Send remaining weight

SRW **x**<CR>

Where **x** selects the channel (1, 2, 3, or 4); if **x** is not specified, all four channels are transmitted. The box to the right shows the response to this command.

```
000000000011111111112222222222233333333334444 4 4
01234567890123456789012345678901234567890123 4 5
Remain 62.5, 45.0, 0, 0 lb<CR><LF>

00000000001111111 1 1
01234567890123456 7 8
Remain 62.5 lb<CR><LF>
```

### Notes:

- <CR> is a carriage-return control character (0dH).
- <LF> is a line-feed control character (0aH).
- The numbers shown in the text boxes (in blue if printed in color) are character indexes for programming purposes.

## RS232 Wiring to PC DB9 Connector

EI-1000/2000	DB9 (PC)	
TB6-3 (C)	5 (SG)	Signal ground
TB6-4 (R)	3 (Tx)	EI' Receive connects to the PC Transmit signal.
TB6-5 (T)	2 (Rx)	EI' Transmit connects to the PC Receive signal.

## **POWER-UP FUNCTIONS**

Power-up functions are activated by, first, powering down the meter, pressing the desired pushbutton combination, and restoring power to the meter.

### **Restore all parameters and calibration to factory default settings.**

This function erases all non-volatile memory and restores the instrument to a factory default setup. The 4-20mA analog outputs, scale inputs and ALL parameters must be checked and changed to proper values to match the scale. **Recalibration of the scale is required.**

EI-1000: [DOWN ARROW] + [SELECT] + [UP ARROW]  
EI-2000: [LEFT UP ARROW] + [LEFT SELECT] + [RIGHT SELECT]

### **Load typical settings for the selected scales.**

This function will load a default scale calibration and setup scale parameters depending on the P100, P200, P300 and P400 selections. The 4-20mA analog output calibration (not full scale) is not altered, but one should check the P6xx parameters to insure that they are set to their proper settings. **Recalibration of the scale is required.**

EI-1000: [DOWN ARROW] + [UP ARROW]  
EI-2000: [LEFT SELECT] + [RIGHT SELECT]

### **Display test**

This function illuminates all 7-segment LED displays and indicator (e.g., gross & remaining) LEDs.

EI-1000: [ZERO] + [DOWN ARROW]                      Exit: [RIGHT ARROW]  
EI-2000: [LEFT ZERO] + [RIGHT ZERO]              Exit: [LEFT UP ARROW]

### **I/O Test mode**

This function cycles the 4-20mA outputs and relays. Also, the keypad pushbuttons, DIP switches and remote input (TB6, IN) functionality can be verified, as well.

EI-1000: [DOWN ARROW] + [RIGHT ARROW]              Exit: [ZERO] + [DOWN ARROW]  
EI-2000: [RIGHT SELECT] + [RIGHT UP ARROW]        Exit: [RIGHT ZERO] + [RIGHT DOWN ARROW]

## HARDWARE

### **TB1 – POWER** - A.C. power connections

1	G	Ground	Earth ground line
2	N	Neutral	Non-fused neutral line
3	H	Hot	Fused line

### **TB2 – RELAYS** – Set point relay contacts

The relays, which are mechanical, can switch 3A, 250V A/C or D/C loads. The power supply is powered externally (dry).

1	L	CH1 contact	Channel 1 low-level or high-level relay contact.
2	+		
3	R	CH2 contact	Channel 2 low-level or high-level relay contact.
4	+		

### **TB3 – ANALOG OUT** – 4-20mA analog outputs

1	+L	CH1 positive signal	Channel 1, active 4-20mA analog output.
2	-L	CH1 negative signal	
3	+R	CH2 positive signal	Channel 2, active 4-20mA analog output.
4	-R	CH2 negative signal	

### **TB4 – CH1 (EI2000-LEFT)** Scale input 1

### **TB5 – CH2 (EI2000-RIGHT)** Scale input 2 (Note: Connections 6 & 7 are not present on TB5)

1	+E	Positive excitation	Positive power supply for the scale base, which is 5V +/- 5%.
2	+S	Positive signal	Positive scale signal input
3	-S	Negative signal	Negative scale signal input
4	-E	Negative excitation	Negative power supply voltage (return) for the scale base, which is 0 volts referenced to signal ground.
5	SH	Shield	Connected to earth ground
6	+	Positive sense	TB4 only: Connected to the negative sense (or negative excitation if the negative sense terminal is not present) at the scale summing board to allow the voltage drop of the cable to be compensated for.
7	-	Negative sense	TB4 only: Connected to the positive sense (or positive excitation if the positive sense terminal is not present) at the scale summing board to allow the voltage drop of the cable to be compensated for.

### **TB6 – Serial I/O and SWITCH INPUT**

1	A	RS485 – A line	Half-duplex RS485 interface.
2	B	RS485 – B line	
3	C	Common	This is signal ground for the RS232, RS485 and switch input, IN.
4	R	RS232 – Rx line	RS232 receive
5	T	RS232 – Tx line	RS232 transmit
6	IN	Switch input	The external, potential free (dry) switch connects to IN and C terminals.

## PORTS & JUMPERS

<b>P1</b>	BDM interface	Factory use only – Do not connect anything to this header.
<b>P2 (J7)</b>	Display interface	This connects, via ribbon cable, to the display, which are the DSP1000 (EI-1000) and EI-2000-DSP.
<b>P3 &amp; P4</b>	Expansion board interface	Both headers are used to connect to expansion boards, which are the EI-2000-IO and EI-2000-EXP.
<b>J1 &amp; J2</b>	Sense connections	Local or remote sense selection shunts.
<b>J3</b>	Instrument selection	This selects an EI-1000, EI-2000 or EI-4000 instrument, see below. <b>This is set at the factory, and if this jumper is not set properly, the meter will not function.</b>
<b>J4</b>	RS485 terminator resistor	Install a shunt to connect the 120 ohm terminator resistor to the RS485 A & B lines.

## FUSE

The fuse is a ½ ampere, 250VAC, 5x20mm, time-lag fuse. **Do not use any other rating.**

## VOLTAGE SELECT SWITCH (S2)

The voltage selection switch, located on the EI-2000S-CPU, selects the 115V or 230V range.

**NOTE: DO NOT SELECT THE VOLTAGE WHILE THE METER IS POWERED!**

## EI-1000 & EI-2000 METER SELECTION HEADER SHUNT (J3)

Connect J3-3 and J3-4 to select an EI-2000 meter; the display is the EI-2000-DSP.

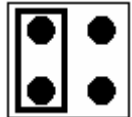

Connect J3-1 and J3-2 to select an EI-1000 meter; the display is the DSP1000.

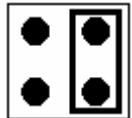

**Invalid shunt positions:**

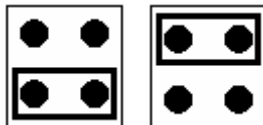

## REMOTE SCALE SENSE

Single channel EI-1000 meters can utilize the remote sense connections. This minimizes the error of the cable voltage drop, minute thermal errors of the connections and wire temperature coefficients. The remote sense must be used if intrinsically-safe barriers are being used. Do not use remote sense on the EI-2000 meter or EI-1000 multi-channel applications.

Disabled (local sense)

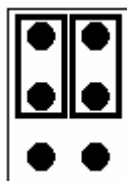

Enabled (remote sense)

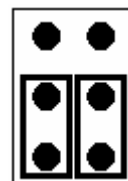

### DIP SWITCH FUNCTION SUMMARY

<b>S1-1</b>	<b>S1-2</b>	<b>OPERATION/SETUP</b>
OFF	OFF	Normal operation (this is the normal setting of these switches)
ON	OFF	Access configuration mode
OFF	ON	Access analog output (4-20mA) test and calibration
ON	ON	Access scale diagnostic and advanced calibration parameters

Note: The calibration DIP switch will override the OPERATION/SETUP switches.

<b>S1-3</b>	<b>WEIGH UNITS</b>
OFF	Pound (lb) scaling
ON	Kilogram (kg) scaling

<b>S1-4</b>	<b>CALIBRATION</b>
OFF	Normal operation (this is the normal setting for this switch)
ON	Calibrate scale w/ dead zero

### MESSAGES

<b>DISPLAY EI-1000</b>	<b>DISPLAY EI-2000</b>	<b>DESCRIPTION</b>
<b>nO O</b>	<b>nO O</b>	No zero – The scale cannot be zeroed since the weight exceeds the value set by the “Push to Zero/Auto-zero PTZ/AZ maximum range” parameter (Px14).
<b>FACTRY</b>	<b>FACTORY</b>	Loading factory default, which is initiated by the user
<b>IIC.Err</b>	<b>IIC.Err</b>	*IIC bus error
<b>AUto.Ld</b>	<b>AUto.LOAd</b>	Automatically loading default configuration & calibration
<b>Add Lb Add KG</b>	<b>Add</b>	Add more weight to the scale before trying to adjust gross weight
<b>EE.Err</b>	<b>EE.Err</b>	*EEPROM device was not found
<b>A OL</b>	<b>A OL</b>	Scale input positive overload
<b>-A OL</b>	<b>-A OL</b>	Scale input negative overload

\* Hardware failure: Return the EI-1000/EI-2000 to factory for service.

---

---

## CONNECTOR WIRING

---

---

### ECS-1501, ECS-1502 and ECS-400 CYLINDER SCALE

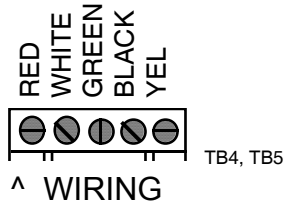

ECS1500 series Load Cell

---

---

### DCS302 DUAL CYLINDER SCALE

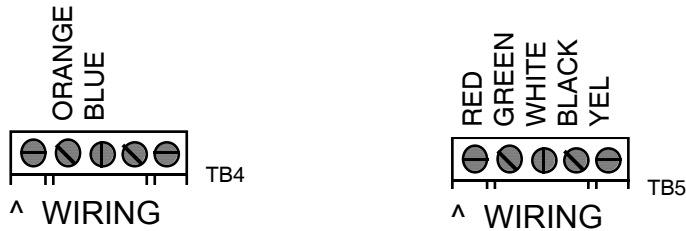

DCS302 Load Cell

DCS302 dual cylinder scales field wiring:  
TB5 connector for Red, Green, White, Black and Yellow wires  
TB4 connector for Blue (- signal) and Orange (+ signal) wires.

---

---

### EDS400, DS750, LP4300, WP1000, CXX00P AND WT3600 SCALES

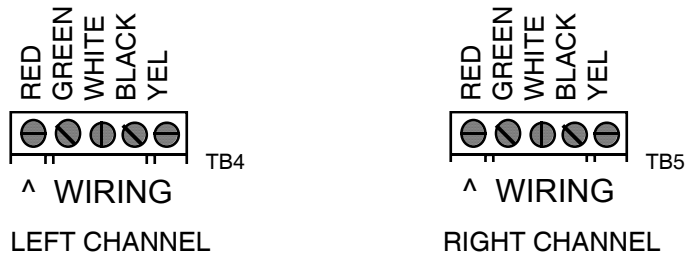

---

---

### BIN AND HOPPER SCALES

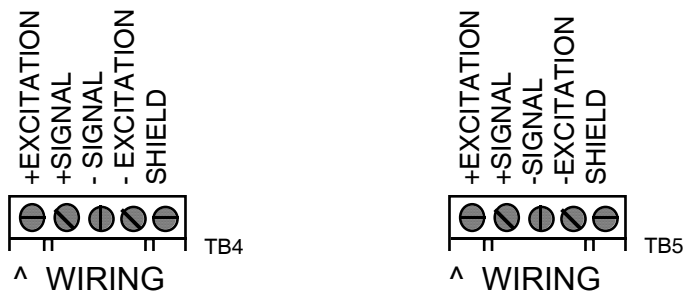

# INSTALLATION

## Wall Mounting Dimensions

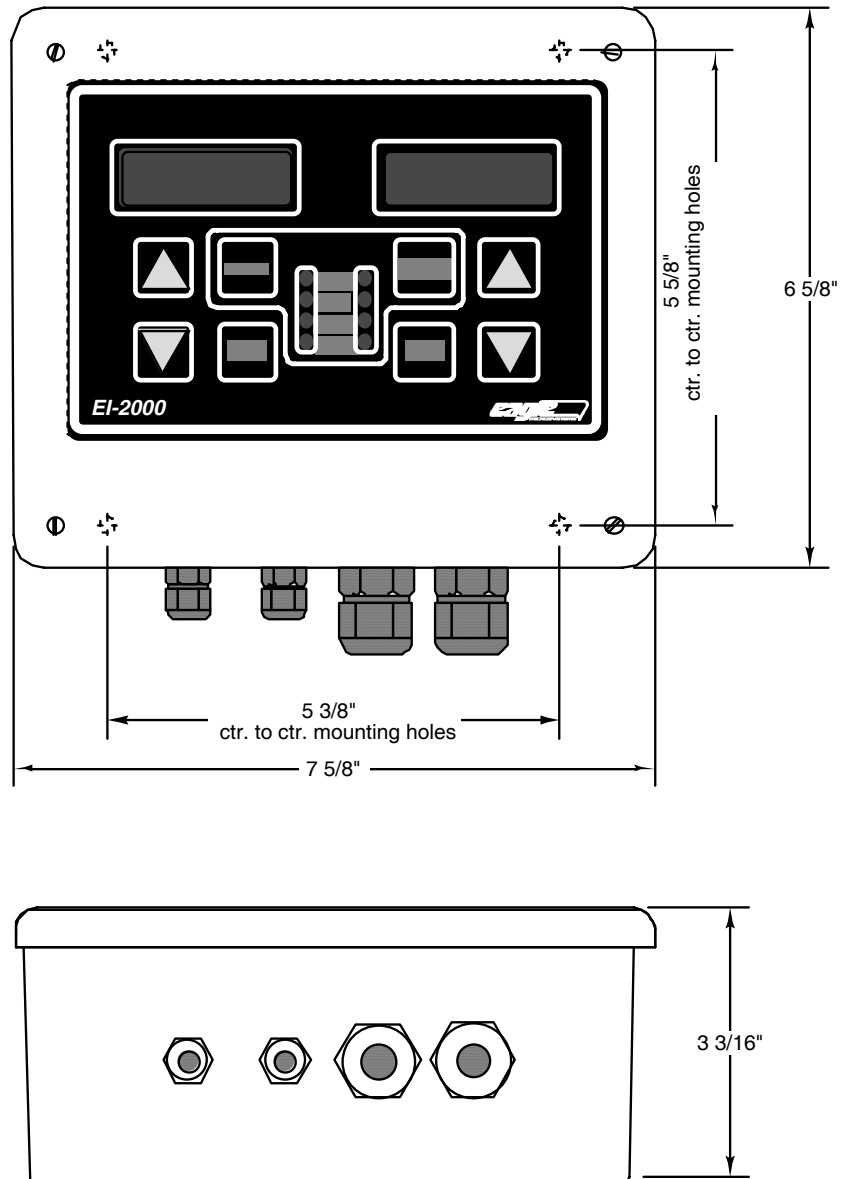

Enclosure conforms to: NEMA 4X

## SPARE PARTS

EI-2000-DSP P/N = 110266  
DSP1000 (EI-1000) = 110271  
CPU P/N = 110394  
EI-2000-IO = 110396  
EI-2000-EXP = 110395  
Interconnecting ribbon cable (8") = 111026

*Page is intentionally blank...*

# EI-1000/EI-2000 ROUTING TICKET

SO # _____	DATE: _____
PROGRAM: _____	SERIAL NUM: _____
VER: _____	BOARD REVISION: _____
<b>CH1 (LEFT) SCALE:</b> _____	<b>CH2 (RIGHT) SCALE:</b> _____
CH1 (LEFT) FULL SCALE: _____	CH2 (RIGHT) FULL SCALE: _____
CH1 (LEFT) SCALE SN: _____	CH2 (RIGHT) SCALE SN: _____
<b>CH3 SCALE:</b> _____	<b>CH4 SCALE:</b> _____
CH3 FULL SCALE: _____	CH4 FULL SCALE: _____
CH3 SCALE SN: _____	CH4 SCALE SN: _____

### SETUP

OPERATION P001 _____	SET POINT MODE #1 P500 _____
lb/kg P010 _____	SET POINT MODE #2 P501 _____
USED P020 _____	ANALOG OUTPUT SEL P600 _____
TARE LOCK P030 _____	BAUD RATE P701 _____
	FRONT PANEL ACCESS P999 _____

### CHANNEL SETUP

<b>SCALE SEL</b>	P100 _____	P200 _____	P300 _____	P400 _____
<b>FULL-SCALE</b>	P110 _____	P210 _____	P310 _____	P410 _____
<b>RESOLUTION</b>	P111 _____	P211 _____	P311 _____	P411 _____
<b>AVERAGE</b>	P112 _____	P212 _____	P312 _____	P412 _____
<b>AUTO-ZERO</b>	P113 _____	P213 _____	P313 _____	P413 _____
<b>PUSH TO ZERO</b>	P114 _____	P214 _____	P314 _____	P414 _____
<b>THRESHOLD</b>	P116 _____	P216 _____	P316 _____	P416 _____
<b>START</b>	P117 _____	P217 _____	P317 _____	P417 _____
<b>SET POINT #1</b>	P510 _____	P520 _____	P530 _____	P540 _____
<b>SET POINT #2</b>	P511 _____	P521 _____	P531 _____	P541 _____
<b>ANALOG F.S.</b>	P610 _____	P620 _____	P630 _____	P640 _____
<b>ZERO CAL</b>	1.0 _____	2.0 _____	3.0 _____	4.0 _____
<b>SPAN CAL</b>	1.c _____	2.c _____	3.c _____	4.c _____

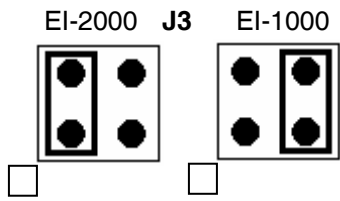

**S2 V. SEL.**

115V

230V

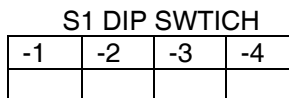
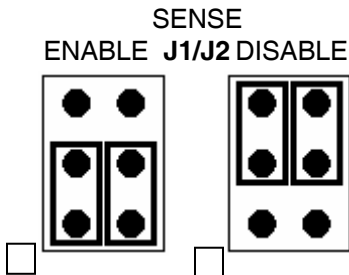

**OPTIONS**

RTC

EI-2000-I/O

EI-2000-EXP

RELAYS

TECH \_\_\_\_\_