

DMS-302

Dual Cylinder Scale



Features

- Large, easy to read display
- Post mounted support bracket with safety chains are standard
- Designed for hostile, high corrosion environments
- Solid PVC scale base is warranted For 5 years
- No special tools needed for installation

DMS-302

Description

The Eagle Microsystems Model DMS302 is a mechanically actuated dual cylinder scale for weighing compressed gas cylinders such as chlorine and sulfur dioxide. It is a true high accuracy scale with a three-beam linkage system. The scale has two independent, solid PVC weighing platforms with dedicated, high-resolution indicators and mechanical tare adjustments.

Materials of construction have been selected to ensure optimum corrosion resistance in the harsh water and wastewater treatment and industrial chemical feed environments. The DMS302 is the standard of the industry in cylinder weighing and is suitable for any compressed gas cylinder application within its dimensional and weight limitations.

Your Source for Precision Process Solutions



DMS-302

Dual Cylinder Scale

Operations

Its low profile makes it easy to roll cylinders onto the platforms without lifting. The cylinders are secured using a post-mounted bracket and safety chains included with the scale. A simple, mechanical tare adjustment is made using the independent adjusting knobs on the indicator head. The net weight is then transmitted to the large, 5 inch, high-resolution analog indicator via a time proven, high reliability lever system. The indicator reads the weight remaining in each cylinder to a true +/- 1% of full scale accuracy.

Display

The weight on each platform is displayed on a separate, 5-inch long analog scale which shows the value of weight remaining to a resolution of 1 lb. (0.5 kg). The indicator, typically graduated 0-150 lbs., can be calibrated in metric units at no additional cost.

Flexibility

The DMS302 is a mechanical dual cylinder scale designed to weigh 150 lb. chlorine and sulfur dioxide cylinders. However, it can be used to weigh any compressed gas cylinder 12-inches or less in diameter and weighing up to 360 lbs. gross weight. Short cylinders can be accommodated by adjusting the height of the post-mounted support bracket.

Warranty

Because of our confidence in the rugged design of this scale, Eagle Microsystems warrants the entire scale against defects in material and workmanship for one year from date of startup. In addition, the scale base is warranted against damage from exposure to corrosive environments for a total period of 5 years.

Physical Specifications

Full Scale(F.S)	360 lbs.
Overload Capacity	150% F.S.
Accuracy	1% F.S.
Cylinder Size	12" Max
Display Calibration	0-150 lbs.
Display Resolution	1 lb.
Operating Temp	0-110° Farenheit

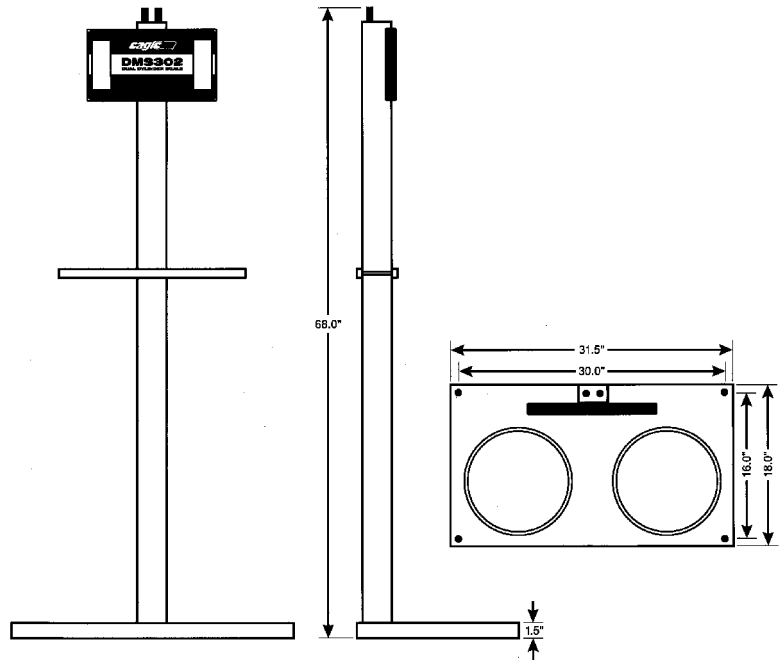

www.EagleMicrosystems.com

Eagle Microsystems Inc. 366 Circle of Progress Pottstown, PA 19464

Telephone: 610.323.2250 800.780.8636 Fax 610.323.0114