

WT-3600

Modular Weigh Trunnion

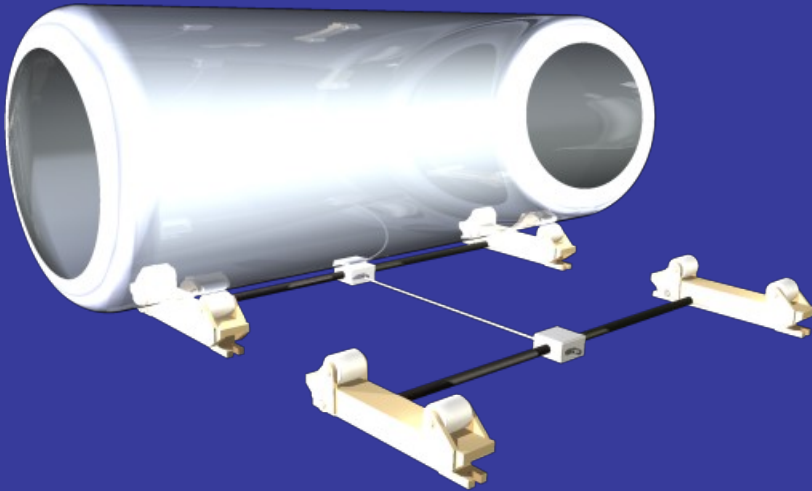

Features

- Expandable to any number of containers
- Easy to install
- Factory assembled
- Rugged cast base for long service life
- All Stainless Steel load cells and hardware

WT-3600

Description

The WT-3600 Weigh trunnion scale is an easy to install, modular, electronic scale for weighting one ton chlorine containers and other similar vessels. Each WT-3600 consists of two roller trunnions fitted with an environmentally sealed stainless steel load cell along with a junction box to provide an electronic reading for a weight indicator.

The weigh trunnions come pre-assembled and field installation is accomplished by simply bolting the assemblies to the floor. The modular nature of this scale means any number of weigh trunnions can be linked together to read the total weight of multiple scales

The trunnions themselves are heavy duty castings with PET plastic rollers for corrosion and impact resistance. The trunnions are patined with an acrylic urethane enamel and wiring for the scales is contained within in a NEMA 4X enclosure to stand up to harsh environments. The trunnions are also sized so that they are entirely within the dimensions of the container for accurate weight measurement. For local readout and signal transmission see our selection of weight indicators.

Your Source for Precision Process Solutions



WT-3600

Modular Weigh Trunnion

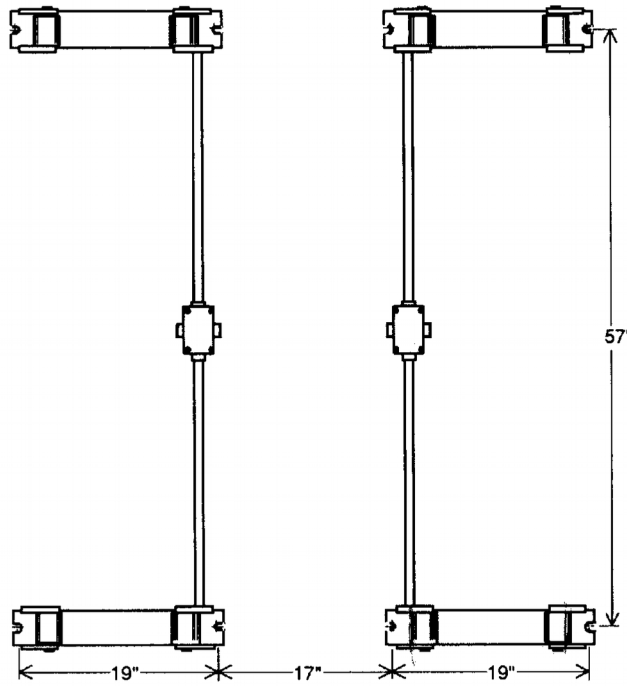

When more than one WT3600 is used the above minimum spacing is recommended.

For installations in seismic active areas, optional earthquake safety straps are available. Order Model SS3600.

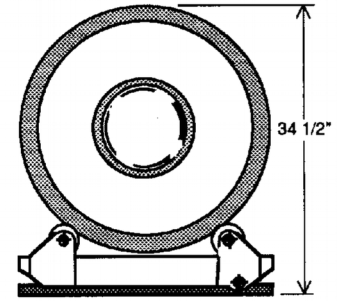

Performance specifications	
Rated capacity(R.C.)	4000 lbs.
Operating accuracy	0.25% R.C.
Nominal output	2 mV/V
Temperature compensation	14° – 104° F
Safe overload	150% R.C.
Load sensing element	Strain gauge load cell
Excitation	5-15 V
Standard cable length	15 ft.
Dimensions	19"X57"X5 1/2" H
Shipping dimensions	25"X23"X7" H
Shipping weight	40 lbs
Roller material	PET-P
Axles	Stainless steel
Finish	Polyester powder coat
Material	Heavy Duty Aluminum

Options	Model
Electronic Indicator	EI series readout
Safety Straps	SS360
Container rotation arm	RA3600
Lifting beam	RT3600
Storage cradles	ST3600
Container Dolly	UD3600



www.EagleMicrosystems.com
Eagle Microsystems Inc. 366 Circle of Progress Pottstown, PA 19464
Telephone: 610.323.2250 800.780.8636 Fax 610.323.0114