

C7200P

Precision Dual Ton Cylinder Scale

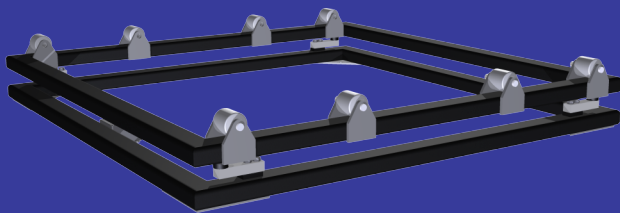

Features

- Four sealed, precision, stainless steel load cells
- Better than 0.1% accuracy
- No pivots or bearings requiring maintenance
- 7" high low profile no scale pit required
- Built-in rollers never require greasing

C7200P

Description

The Eagle Microsystems C7200P dual ton cylinder scale is designed specifically for the water treatment industry. It is constructed from a corrosion protected steel box frame for years of reliable service. Four stainless steel strain gauge load cells are used to weigh the load providing accuracy in excess of 0.1% of rated capacity. Overload stops and all stainless steel hardware are standard on every scale. This scale is suitable for weighing standard chlorine, sulphur dioxide and many similarly sized containers. If you are looking for the optimal scale to control your chemical inventory the C7200P is a great choice.

The C7200P is designed to meet the requirements of NIST handbook #44. The scale is designed with the frame and loadcells within the dimensions of the container for optimal accuracy in weighing. Roller trunnions are non-corroding PET plastic with stainless steel axles to allow ease of rotation for containers without the need for lubrication or maintenance.

Your Source for Precision Process Solutions



C7200P

Precision Dual Ton Scale

Specifications	
Performance	
Rated capacity	8000 lbs. (3600 kg)
Operating accuracy	0.1% of rated capacity
Electrical	
Load sensing element	Shear beam strain gauge
Excitation	5-15 V dc
Electrical connection	15 ft. of 6 conductor cable
Materials of construction	
Frames	Cold rolled steel
Load cells	17-4 stainless steel
Shock isolator	Fabreeka®
Load specifications	
Safe overload	200% rated capacity
Ultimate overload	400% rated capacity
Dimensions	5'X5'X7"H
Options	
Safety straps	SS3600
Extended rollers	
Container rotation arm	RA3600
Universal dolly for transportation	UD3600
Storage roller trunnions	RT3600
Storage cradles	ST3600

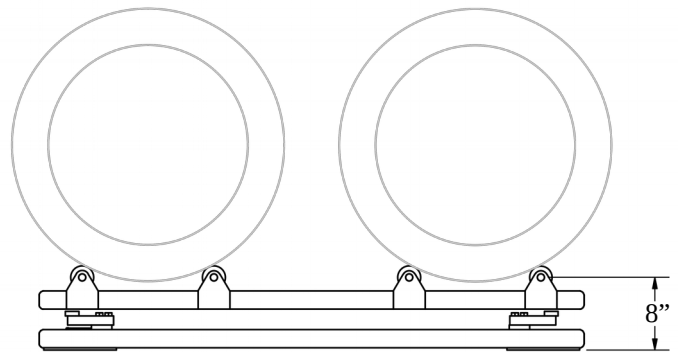
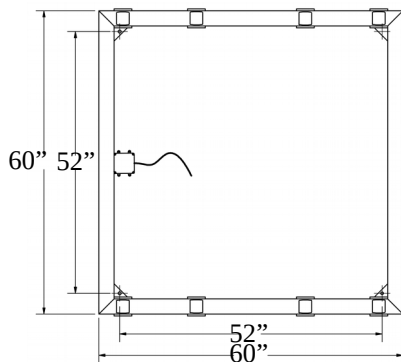

www.EagleMicrosystems.com

Eagle Microsystems Inc. 366 Circle of Progress Pottstown, PA 19464

Telephone: 610.323.2250 800.780.8636 Fax 610.323.0114